

INTERNAL DIMENSIONS RETORT	720mm x 720mm x 800mm high
EXTERNAL DIMENSIONS FURNACE	1100mm x 1250mm x 1600mm high approx. excluding the condenser, carbon filter and vacuum pump.
METAL EXTERNAL FRAME	50 x 50 x 6 mm angle 0.9 S/S 304 sheeting 20mm, 8mm, 6mm, 3mm plate.
INTERNAL RACKING SYSTEM	316 S/S 40x 40 x 5mm angle rack (7 Positions) 253MA S/S 3mm plate trays 650 x 650 x 90 high (7 off) All fully pacified and stress relieved.
INSULATION	115mm thick refractory brick recess grooved to take elements on three sides and the Floor. Total Insulation will be a minimum of 200mm thick Maximum temperature 1280°C
RETORT	253MA S/S 3mm plate fully welded. 15mm & 10mm plate 310 S/S Maximum temperature 900°C Suggested best operating temperature 500°C

CONTACT US

P: +61 8 9417 4226 | F: +61 8 9417 9827

E-Mail: sales@furnace-technologies.com.au

www.furnace-technologies.com.au

Furnace Technologies Pty Ltd

60 Cutler Road, Jandakot, WA 6164

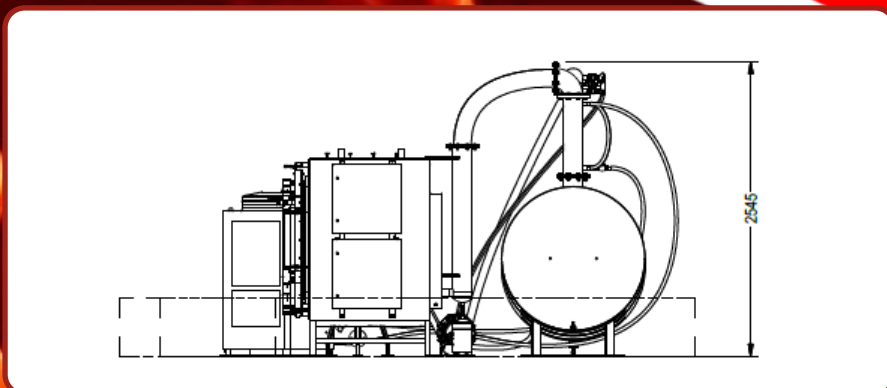
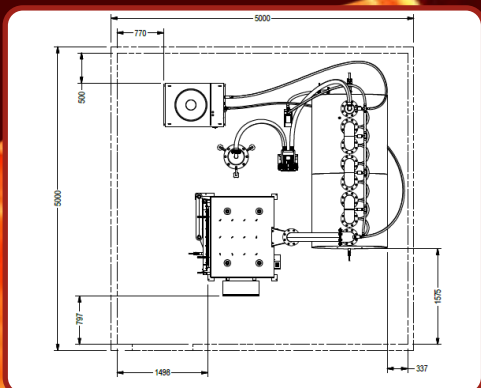

CONTROLS

Main Control **PFY700** temperature control. This control will enable the user to set the required temperature profile. It will also control step up and down in the Vacuum Pump.

Safety lockout. A separate system will monitor the maximum attainable temperature. If this temperature is reached the unit will hold it back if the temperature rises a further 10°C it goes to lockout and sounds an alarm. The system must be re-set to re-enable the main controls.

A third control monitors the exit air temperature from the condenser with an audible alarm and temperature hold back.

A Pressure switch monitors the pressures in the train with warning alarms and lockout.

A temperature control monitors the incoming cooling water supply from the chiller. Sounds an alarm with temperature hold back.

A VSD controls the vacuum pump which is pre-set for correct operation.

A sensor warns of over full condenser

CONTROL ENCLOSURE

The control enclosure rated at IP64

Element Terminations are not rated, they prevent water ingress interfering with the terminations by deflecting water flow.

CONDENSER SYSTEM.

A S/S 316 tank angled so as to collect the mercury at the base.

5 condensing columns.

Primary mercury collection point.

Flexible connection S/S.

Secondary mercury collection point. Clear tube fills with the heavy metals collected displacing the water.

Fitted with sight glass to determine correct water level and to view the build up of product from the retort. This unit will need to be drained every week or so depending upon how much water is collected.

A sensors detects the rise of water in the condenser and sounds an alarm.

Voltage free contacts available for all alarms.

VACUUM PUMP

Side channel ring blower controlled via a VSD. This is controlled Via Pressure sensors on the Retort. The Amount of vacuum pulled is dependant upon the process considerations and time factors. Factors that can affect the needed vacuum are exothermic reactions in the process ore.

CONTACT US

P: +61 8 9417 4226 | F: +61 8 9417 9827

E-Mail: sales@furnace-technologies.com.au

www.furnace-technologies.com.au

Furnace Technologies Pty Ltd

60 Cutler Road, Jandakot, WA 6164